

(12) INTERNATIONAL APPLICATION PUBLISHED UNDER THE PATENT COOPERATION TREATY (PCT)

(19) World Intellectual Property Organization  
International Bureau



(43) International Publication Date  
19 December 2002 (19.12.2002)

PCT

(10) International Publication Number  
WO 02/100251 A2

- (51) International Patent Classification: A61B
- (21) International Application Number: PCT/US02/19053
- (22) International Filing Date: 12 June 2002 (12.06.2002)
- (25) Filing Language: English
- (26) Publication Language: English
- (30) Priority Data:  
60/298,001 12 June 2001 (12.06.2001) US
- (63) Related by continuation (CON) or continuation-in-part (CIP) to earlier application:  
US 60/298,001 (CIP)  
Filed on 12 June 2001 (12.06.2001)
- (71) Applicant (for all designated States except US): PE-  
LIKAN TECHNOLOGIES, INC. [US/US]; 1072 East  
Meadow Circle, Palo Alto, CA 94303 (US).
- (72) Inventors; and
- (75) Inventors/Applicants (for US only): ALDEN, Don  
[US/US]; 1312 Nelson Way, Sunnyvale, CA 94087 (US).  
FREEMAN, Dominique, M. [GB/US]; 4545 La Honda  
Road, La Honda, CA 94020 (US).
- (74) Agents: TUNG, Hao, Y. et al.; Heller Ehrman White &  
McAuliffe LLP, 275 Middlefield Road, Menlo Park, CA  
94025-3506 (US).
- (81) Designated States (national): AE, AG, AL, AM, AT, AU,  
AZ, BA, BB, BG, BR, BY, BZ, CA, CH, CN, CO, CR, CU,  
CZ, DE, DK, DM, DZ, EC, EE, ES, FI, GB, GD, GE, GH,  
GM, HR, HU, ID, IL, IN, IS, JP, KE, KG, KP, KR, KZ, LC,  
LK, LR, LS, LT, LU, LV, MA, MD, MG, MK, MN, MW,  
MX, MZ, NO, NZ, OM, PH, PL, PT, RO, RU, SD, SE, SG,  
SI, SK, SL, TJ, TM, TN, TR, TT, TZ, UA, UG, US, UZ,  
VN, YU, ZA, ZM, ZW.

[Continued on next page]

(54) Title: SELF OPTIMIZING LANCING DEVICE WITH ADAPTATION MEANS TO TEMPORAL VARIATIONS IN CUTA-  
NEOUS PROPERTIES

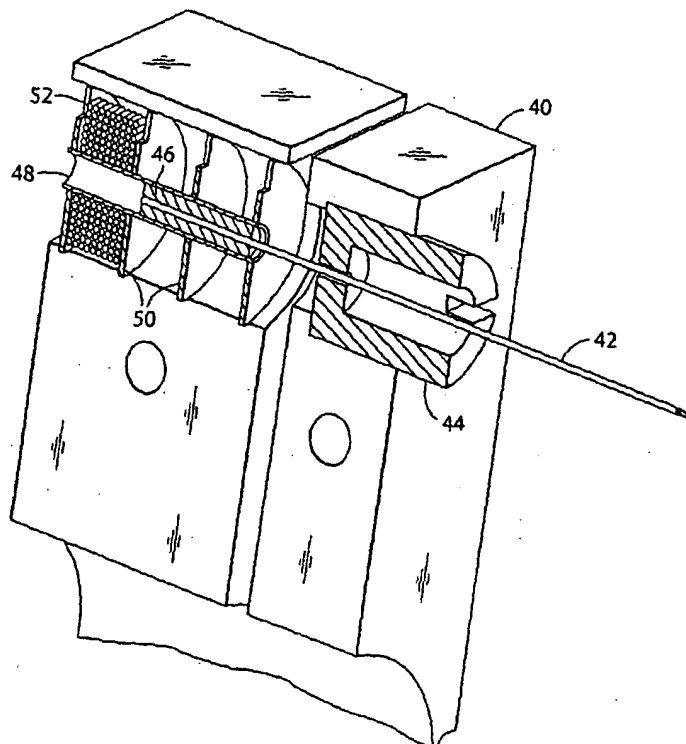

(57) Abstract: A lancet device, an embodiment of which controls the advancement and retraction of a lancet by monitoring the position of the lancet in conjunction with a lancet controller which incorporates a feedback loop for modulating the lancet driver to follow a predetermined tissue lancing profile.

WO 02/100251 A2



**(84) Designated States (regional):** ARIPO patent (GH, GM, KE, LS, MW, MZ, SD, SL, SZ, TZ, UG, ZM, ZW), Eurasian patent (AM, AZ, BY, KG, KZ, MD, RU, TJ, TM), European patent (AT, BE, CH, CY, DE, DK, ES, FI, FR, GB, GR, IE, IT, LU, MC, NL, PT, SE, TR), OAPI patent (BF, BJ, CF, CG, CI, CM, GA, GN, GQ, GW, ML, MR, NE, SN, TD, TG).

PL, PT, RO, RU, SD, SE, SG, SI, SK, SL, TJ, TM, TN, TR, TT, TZ, UA, UG, UZ, VN, YU, ZA, ZM, ZW, ARIPO patent (GH, GM, KE, LS, MW, MZ, SD, SL, SZ, TZ, UG, ZM, ZW), Eurasian patent (AM, AZ, BY, KG, KZ, MD, RU, TJ, TM), European patent (AT, BE, CH, CY, DE, DK, ES, FI, FR, GB, GR, IE, IT, LU, MC, NL, PT, SE, TR), OAPI patent (BF, BJ, CF, CG, CI, CM, GA, GN, GQ, GW, ML, MR, NE, SN, TD, TG)

**Declaration under Rule 4.17:**

— as to the applicant's entitlement to claim the priority of the earlier application (Rule 4.17(iii)) for the following designations AE, AG, AL, AM, AT, AU, AZ, BA, BB, BG, BR, BY, BZ, CA, CH, CN, CO, CR, CU, CZ, DE, DK, DM, DZ, EC, EE, ES, FI, GB, GD, GE, GH, GM, HR, HU, ID, IL, IN, IS, JP, KE, KG, KP, KR, KZ, LC, LK, LR, LS, LT, LU, LV, MA, MD, MG, MK, MN, MW, MX, MZ, NO, NZ, OM, PH,

**Published:**

— without international search report and to be republished upon receipt of that report

For two-letter codes and other abbreviations, refer to the "Guidance Notes on Codes and Abbreviations" appearing at the beginning of each regular issue of the PCT Gazette.

SELF OPTIMIZING LANCING DEVICE WITH ADAPTATION MEANS  
TO TEMPORAL VARIATIONS IN CUTANEOUS PROPERTIES

TECHNICAL FIELD

Lancing devices are well known in the medical health-care products industry for piercing the skin to produce blood for analysis. Biochemical analysis of blood samples is a diagnostic tool for determining clinical information. Many point-of-care tests are performed using capillary whole blood, the most common being monitoring diabetic blood glucose level. Other uses for this method include the analysis of coagulation based on Prothrombin time measurement. Typically, a drop of blood for this type of analysis is obtained by making a small incision in the fingertip, creating a small wound, which generates a small blood droplet on the surface of the skin.

BACKGROUND ART

Early methods of lancing included piercing or slicing the skin with a needle or razor. Current methods utilize lancet drivers that contain a multitude of spring, cam and mass actuators to drive the lancet. These include cantilever springs, diaphragms, coil springs, as well as gravity plumbs used to actuate the lancet. Typically, the device is pre-cocked, or the user cocks the device. The device is held against the skin and the user, or pressure from the users skin, mechanically triggers the ballistic launch of the lancet. The forward movement, and depth of skin penetration of the lancet is determined by a mechanical stop and/or damping, as well as a spring or cam which retract the lancet.

Current devices generally rely on adjustable mechanical stops or damping to control the lancet's depth of penetration to compensate for skin thickness and hydration. Such devices have the possibility of multiple strikes due to recoil, in addition to vibratory stimulation of the severed nerves as the driver impacts the end of the launcher stop. Cams may offer rough control of lancet velocity in and out of the skin, but do not allow for compensation for skin thickness and hydration. Variations in skin thickness

and hydration may yield different results in terms of pain perception, blood yield and success of obtaining blood from different users of the lancing device.

### DISCLOSURE OF INVENTION

5 Embodiments of the present invention are related to medical health-care products and to methods for obtaining body fluids for chemical analysis. More particularly, embodiments of the invention relate to devices and methods for piercing the skin (lancing) using an electrically driven lancet having user definable lancet parameters such as lancet displacement, velocity of incision, retraction, acceleration, and tissue dwell  
10 time. A device having features of the invention can compensate for long-term changes in skin physiology, nerve function, and peripheral vascular perfusion such as occurs in diabetes, as well as diurnal variation in skin tensile properties. Alternatively, a device having features of the invention can compensate for skin differences between widely differing populations such as pediatric and geriatric patients.

15 An embodiment of the invention is directed to a lancing device which controls the advancement and retraction of a lancet by monitoring the position of the lancet in conjunction with a control feedback for modulating the lancet driver to follow a predetermined profile.

### BRIEF DESCRIPTION OF DRAWING

20 The objects, advantages and features of this invention will be more readily appreciated from the following detailed description, when read in conjunction with the accompanying drawing, in which:

Figures 1A and 2A illustrate the displacement over time profile of a harmonic spring/mass system and a controlled lancet.

25 Figures 1B and 2B illustrate the velocity over time profiles of a harmonic spring/mass system and a controlled lancet.

Figure 3 illustrates a controlled actuator using an electromagnetic actuator to drive the lancet.

Figure 4 is a flowchart illustrating a controlled feed-back loop.

Figure 5 is a graph of force vs. time during the advancement and retraction of a lancet showing the characteristic phases of the lancing cycle.

#### BEST MODE FOR CARRYING OUT THE INVENTION

5 Lancing device is generally defined to mean any self-contained device for puncturing the skin for the purpose of obtaining a body fluid sample. Lancing devices are typically disposable and reusable in their entirety, or in part. For example, some lancing devices are disposed of as biohazards after one usage. Other lancing devices dispose of only the portions that come in contact with the skin.

10 Lancet is generally defined to mean any sharp or blunt member used to puncture the skin for the purpose of cutting blood vessels and allowing blood to flow to the surface of the skin. The lancet has certain parameters such as diameter to define the cross-sectional area of the member, and geometry to define the shape of the distal or front lancing end of the member.

15 Lancet driver is generally defined to mean any means for controlling the advancement and retraction of the lancet. Examples of lancet drivers can include spring-actuated drivers, electromagnetic drivers and piezoelectric drivers. Examples of electromagnetic drivers include solenoids, linear induction motors, and linear reluctance motors.

20 Feedback loop is generally defined to mean a feedback control loop where information is collected about the current behavior of the lancet (such as relative lancet position, rate and direction of lancet motion, resistance to lancet motion, etc.) and is used to modulate the drive power applied to the lancet.

25 Processor is generally defined to mean a high-speed digital processor containing memory and calculation capabilities. Such processor is used to modulate the lancet driver. Modulate is generally defined to mean controlling the profile of the lancet.

Profile is generally defined to mean a displacement, velocity or acceleration versus time plot or table.

30 Typically, the lancet and the lancet driver are configured so that lancet velocity is high at the moment of first contact with the skin, decelerates to zero at the predetermined penetration depth, and immediately retracts from the skin, leaving at

approximately the same velocity that it entered. The energy required for lancet actuation is initially stored as potential energy, as in the actuators discussed above. During the lancing cycle, the stored energy is transferred into the kinetic energy of the lancet, which is then transferred to potential energy at the apex of the trajectory, and is immediately transferred back into kinetic energy by the retraction mechanism. The actuation and retraction velocities are similar, though opposite in sign. The devices which employ spring or cam driving methods have a symmetrical actuation displacement and velocity profile on the advancement and retraction of the lancet. In most of the available lancet devices, once the launch is initiated, the stored energy determines the velocity profile until the energy is dissipated. Piezoelectric assisted cutting methods have also been described; however, the launching mechanism is spring driven, and no feedback is described for controlling lancet motion. Variations in skin properties require controlling impact, retraction velocity, and dwell time of the lancet within the tissue.

Advantages are achieved by taking into account that tissue dwell time is related to the amount of skin deformation as the lancet tries to puncture the surface of the skin and variance in skin deformation from patient to patient based on skin hydration with regard to dwell time and the necessity to achieve at least 100 microns of skin depth to successfully sample blood.

Pain reduction can be achieved through both the rapid lancet cutting speed and light weight of the proposed lancet. The rapid cutting minimizes the shock waves produced when the lancet strikes the skin in addition to compressing the skin for efficient cutting. Due to the very light mass of the lancet and lack of mechanical stop, there is insubstantial or no vibrational energy transferred to the finger during cutting.

Lancing devices such as the spring and cam driven devices typically yield 70 – 80 % success rate in obtaining a blood droplet, as some lancing events are unsuccessful. Success rate is dependent on reaching the blood capillaries and venuoles, which yield the blood sample. Due to variation in skin thickness and hydration, some skin will deform more before cutting starts, and hence the actual depth of penetration will be less, resulting in less capillaries and venuoles cut. An electronic feedback mechanism yields accurate measurement of skin resistance, and therefore depth of penetration and thus directly improves the success rate of blood yield.

Spontaneous blood yield occurs when blood from the cut vessels flows up the wound tract to the surface of the skin, where it can be collected and tested. Tissue elasticity parameters may force the wound tract to close behind the retracting lancet preventing the blood from reaching the surface. If however, the lancet were to dwell  
5 before being retracted, and or be withdrawn slowly from the wound tract, thus keeping the wound open, blood could flow up the patent channel, as described in a copending application (Attorney Docket Number 38187-2556, Inventors: Boecker, et al., entitled "METHOD AND APPARATUS FOR IMPROVING SUCCESS RATE OF BLOOD  
10 YIELD FROM A FINGERSTICK") submitted on the same day and assigned to the same assignee as the present application. Said copending application is incorporated by reference in its entirety herein.

The ability to control the lancet speed into and out of the wound is critical as it allows the device to compensate for changes in skin thickness and variations in skin hydration to achieve spontaneous blood yield with maximum success rate while  
15 minimizing pain. This is done by taking into consideration the skin deformation to achieve a desirable tissue dwell time and depth of penetration.

This ability to control velocity and depth of penetration therefore requires an actuation mechanism where feedback is an integral part of driver control. An example of such a driver is the electromagnetic actuator design as described in a copending  
20 application (Attorney Docket Number 38187-2551, Inventors: Don Alden, et al., entitled "ELECTRIC LANCET ACTUATOR") submitted on the same day and assigned to the same assignee as the present application. Said copending application is incorporated by reference in its entirety herein. Such drivers can control either metal or polymeric  
25 lancets. The dynamic control of such a driver is shown in Figure 2A which illustrates the controlled displacement profile and Figure 2B which illustrates the controlled velocity profile. These are compared to Figures 1A and 1B which illustrate the displacement and velocity profiles, respectively, of a harmonic spring/mass system.

It is, accordingly, an advantage to control the lancet displacement, velocity, and acceleration at several steps in the lancing cycle. Such control increases the success rate  
30 of obtaining an acceptable sample volume of blood and the ability to obtain a spontaneous blood sample, and decreases the pain perceived by the patient during the

lancing procedure. Reduced pain is achieved because of fast entry of the lancet into the tissue. Reduced lancet velocity with increased lancet dwell time in the tissue at a point where the lancet intersects the venuoles and capillary mesh, allows the blood to pool, promoting uninhibited flow into the exit channel. Retraction of the lancet at a low velocity following the sectioning of the venuole/capillary mesh allows the blood to flood the wound tract and flow freely to the surface, thus using the lancet to keep the channel open during retraction. Low-velocity retraction of the lancet near the wound flap prevents the wound flap from sealing off the channel. Thus, the ability to slow the lancet retraction directly contributes to increasing the success rate of obtaining blood. Increasing the sampling success rate to near 100% is considered an essential prerequisite to combine sampling and acquisition into an integrated sampling module (e.g. an integrated glucose sampling module which incorporates a glucose test strip).

Reference will now be made to exemplary embodiments of the invention. In the first embodiment, a lancing device contains a lancet and lancet driver. The lancet and lancet driver are configured so that feedback control is based on lancet displacement, velocity, or acceleration. The feedback control information relating to the actual lancet path is returned to a processor that regulates the energy to the lancet driver, thereby precisely controlling the lancet throughout its advancement and retraction. The lancet driver may be driven by electric current which includes direct current and alternating current. Figure 3 shows an electromagnetic type lancet driver that is capable of driving an iron core mounted to the lancet assembly using a direct current (DC) power supply. The solenoid is divided into three separate coils along the path of the lancet, two end coils and a middle coil. Direct current is applied to the coils to advance and retract the lancet. The coils are used in pairs to draw the iron core into the solenoid. As one of the drive coils is switched on, the corresponding induced current in the adjacent coil is monitored. The strength of this induced current is related to the degree of magnetic coupling provided by the iron core, and can be used to infer the position of the core. After a period of time, the drive voltage is turned off, allowing the coils to relax, and then the cycle is repeated. The degree of magnetic coupling between the coils is converted electronically to a proportional DC voltage that is supplied to an analog-to-digital converter. The digitized position signal is then processed and compared to a



desired "nominal" position by a central processing unit (CPU). Error between the actual and nominal positions is used by the CPU to set the level and/or length of the next power pulse to the solenoid coils.

Referring to FIG. 3, the stationary housing (40) contains the solenoid whose first  
5 coil (52) is separated by a magnetically permeable spacer (50) from the adjacent coil. The housing (40) is made from a magnetically permeable material, and a magnetically permeable spacer is assembled outside of the first coil. The spacers and housing form a magnetic circuit that focuses the magnetic field produced by the coil between the inner  
10 diameter edges of the spacers. The same is true of each of the other coils, the housing, and their spacers. The inner guide tube (48) isolates the lancet (42) and iron core (46) from the solenoid coils (52). The lancet (42) and iron core (46) are centered by the lancet guide (44). The lancet (42) is advanced and retracted by alternating the current  
15 between the first coil (52), the middle coil (not shown), and the third coil (not shown), singly or in combination, to advance or retract the iron core (46). The lancet guide (44) also serves as a stop for the iron core (46) mounted to the lancet (42).

In another embodiment, the solenoid comprises three coils consisting of a central driving coil flanked by balanced detection coils built into the driver assembly so that they surround the actuation region with the region centered on the middle coil at mid-stroke. When a current pulse is applied to the central coil, voltages are induced in the  
20 adjacent sense coils. If the sense coils are connected together so that their induced voltages oppose each other, the resulting signal will be positive for deflection from mid-stroke in one direction, negative in the other direction, and zero at mid-stroke. This measuring technique is commonly used in Linear Variable Differential Transformers (LVDT). Lancet position is determined by measuring the electrical balance between the  
25 two sensing coils.

In another embodiment, the feedback loop uses a commercially available LED/photo transducer module such as the OPB703 (manufactured by Optek Technology, Inc., 1215 W. Crosby Road, Carrollton, Texas, 75006 (972) 323-2200) to determine the distance from the fixed module on the stationary housing to a reflective surface or target  
30 mounted on the lancet assembly. The LED acts as a light emitter to send light beams to the reflective surface which in turn reflects the light back to the photo transducer

which acts as a light sensor. Distances over the range of 4mm or so are determined by measuring the intensity of the reflected light by the photo transducer.

In another embodiment, the feed-back loop uses a magnetically permeable region on the lancet shaft itself as the core of a Linear Variable Differential Transformer (LVDT). A permeable region created by selectively annealing a portion of the lancet shaft, or by including a component in the lancet assembly, such as ferrite, with sufficient magnetic permeability to allow coupling between adjacent sensing coils. Coil size, number of windings, drive current, signal amplification, and air gap to the permeable region are specified in the design process.

In another embodiment, the feedback control supplies a piezoelectric driver, superimposing a high frequency oscillation on the basic displacement profile. The piezoelectric driver provides improved cutting efficiency and reduces pain by allowing the lancet to "saw" its way into the tissue or to destroy cells with cavitation energy generated by the high frequency of vibration of the advancing edge of the lancet. The drive power to the piezoelectric driver is monitored for an impedance shift as the device interacts with the target tissue. The resulting force measurement, coupled with the known mass of the lancet is used to determine lancet acceleration, velocity, and position.

Figure 4 shows the operation of the feedback loop using the processor. The processor (60) stores profiles (62) in non-volatile memory. A user inputs information (64) about the desired circumstances for the lancing event. The processor (60) selects a profile (62) from a set of alternative profiles that have been preprogrammed in the processor (60) based on typical device performance determined through testing at the factory. The processor (60) may customize by either scaling or modifying the profile based on additional user input information (64). Once the processor has chosen and customized the profile, the processor (60) is ready to modulate the power from the power supply (66) to the lancet driver (68) through an amplifier (70). The processor (60) measures the location of the lancet (72) using a position sensing mechanism (74) through an analog to digital converter (76). Examples of position sensing mechanisms have been described in the embodiments above. The processor (60) calculates the movement of the lancet by comparing the actual profile of the lancet to the predetermined profile. The processor (60) modulates the power to the lancet driver (68)

through a signal generator (78), which controls the amplifier (70) so that the actual profile of the lancet does not exceed the predetermined profile by more than a preset error limit. The error limit is the accuracy in the control of the lancet.

5 After the lancing event, the processor (60) allows the user to rank the results of the lancing event. The processor (60) stores these results and constructs a database (80) for the individual user. Using the database (80), the processor (60) calculates the profile traits such as degree of painlessness, success rate, and blood volume for various profiles (62) depending on user input information (64) to optimize the profile to the individual user for subsequent lancing cycles. These profile traits depend on the characteristic  
10 phases of lancet advancement and retraction. The processor (60) uses these calculations to optimize profiles (62) for each user. In addition to user input information (64), an internal clock allows storage in the database (80) of information such as the time of day to generate a time stamp for the lancing event and the time between lancing events to anticipate the user's diurnal needs. The database stores information and statistics for  
15 each user and each profile that particular user uses.

In addition to varying the profiles, the processor calculates the appropriate lancet diameter and geometry necessary to realize the blood volume required by the user. For example, if the user requires a 1-5 microliter volume of blood, the processor selects a 200 micrometer lancet diameter to achieve these results. For each class of lancet, both  
20 diameter and lancet tip geometry, is stored in the processor to correspond with upper and lower limits of attainable blood volume based on the predetermined displacement and velocity profiles.

The lancing device is capable of prompting the user for information at the beginning and the end of the lancing event to more adequately suit the user. The goal  
25 is to either change to a different profile or modify an existing profile. Once the profile is set, the force driving the lancet is varied during advancement and retraction to follow the profile. The method of lancing using the lancing device comprises selecting a profile, lancing, determining lancing profile traits for each characteristic phase of the lancing cycle, and optimizing for subsequent lancing events.

30 Figure 5 shows the characteristic phases of lancet advancement and retraction on a graph of force versus time illustrating the force exerted by the lancet driver on the

lancet to achieve the desired displacement and velocity profile. The characteristic phases are the lancet introduction phase A-C where the lancet is longitudinally advanced into the skin, the lancet rest phase D where the lancet terminates its longitudinal movement reaching its maximum depth and becoming relatively stationary, and the lancet retraction phase E-G where the lancet is longitudinally retracted out of the skin. The duration of the lancet retraction phase E-G is longer than the duration of the lancet introduction phase A-C, which in turn is longer than the duration of the lancet rest phase D.

The introduction phase further comprises a lancet launch phase prior to A when the lancet is longitudinally moving through air toward the skin, a tissue contact phase at the beginning of A when the distal end of the lancet makes initial contact with the skin, a tissue deformation phase A when the skin bends depending on its elastic properties which are related to hydration and thickness, a tissue lancing phase which comprises when the lancet hits the inflection point on the skin and begins to cut the skin B and the lancet continues cutting the skin C. The lancet rest phase D is the limit of the penetration of the lancet into the skin. Pain is reduced by minimizing the duration of the lancet introduction phase A-C so that there is a fast incision to a certain penetration depth regardless of the duration of the deformation phase A and inflection point cutting B which will vary from user to user. Success rate is increased by measuring the exact depth of penetration from inflection point B to the limit of penetration in the lancet rest phase D. This measurement allows the lancet to always, or at least reliably, hit the capillary beds which are a known distance underneath the surface of the skin.

The lancet retraction phase further comprises a primary retraction phase E when the skin pushes the lancet out of the wound tract, a secondary retraction phase F when the lancet starts to become dislodged and pulls in the opposite direction of the skin, and lancet exit phase G when the lancet becomes free of the skin. Primary retraction is the result of exerting a decreasing force to pull the lancet out of the skin as the lancet pulls away from the finger. Secondary retraction is the result of exerting a force in the opposite direction to dislodge the lancet. Control is necessary to keep the wound tract open as blood flows up the wound tract. Blood volume is increased by using a uniform velocity to retract the lancet during the lancet retraction phase E-G regardless of the

force required for the primary retraction phase E or secondary retraction phase F, either of which may vary from user to user depending on the properties of the user's skin.

Other embodiments of the invention will be apparent to those skilled in the art from consideration of the specification and practice of the invention disclosed herein.

5 It is intended that the specification and examples be considered as exemplary only, with a true scope and spirit of the invention being indicated by the following claims.

CLAIMS

1. A lancing device comprising:  
a lancet comprising a shaft having a proximal driving end and a distal  
lancing end;  
a lancet driver coupled to said lancet for longitudinal displacement of said  
lancet; and  
5 a lancet controller coupled to said lancet driver, said lancet controller  
comprising a feedback loop for monitoring the longitudinal displacement  
of said lancet and for modulating the lancet driver to provide a  
predetermined tissue lancing profile having characteristic phases for  
10 lancet advancement and retraction.
2. A lancing device according to claim 1 wherein:  
said lancet driver comprises a solenoid.
- 15 3. A lancing device according to claim 2 wherein:  
said solenoid drives the lancet with electric current.
4. A lancing device according to claim 3 wherein:  
said lancet controller comprises additional coil segments disposed  
20 adjacent to said solenoid for monitoring the lancet displacement.
5. A lancing device according to claim 1 wherein:  
said lancet driver comprises a means for oscillating the lancet to improve  
the lancet cutting ability.
- 25 6. A lancing device according to claim 5 wherein:  
said oscillating means comprises a piezoelectric driver.

- 5
7. A lancing device according to claim 6 wherein:  
said lancet controller controllably varies said tissue lancing profile as a  
function of impedance changes sensed from said piezoelectric driver  
resulting from said lancet interacting with said tissue.
8. A lancing device according to claim 5 wherein:  
said lancet controller comprises a means for sensing a change in lancing  
pressure to determine the lancet displacement.
- 10
9. A lancing device according to claim 1 wherein:  
said lancet controller comprises a processor for modulating the lancet  
driver.
- 15
10. A lancing device according to claim 9 wherein:  
said processor comprises memory for storage and retrieval of a set of  
alternative lancing profiles which the processor uses to modulate the  
lancet driver.
- 20
11. A lancing device according to claim 10 wherein:  
a user of said lancing device selects the profile desired from said set of  
alternative profiles to modulate the lancet.
- 25
12. A lancing device according to claim 9 wherein:  
said processor optimizes said phases of said tissue lancing profile based  
on information entered by the user of said lancing device.
- 30
13. A lancing device according to claim 9 wherein:  
said processor modulates the lancet driver by comparing an actual profile  
of the lancet to the profile and maintaining a preset error limit between  
the actual profile and the profile.

14. A lancing device according to claim 9 wherein:  
said processor comprises a database for the user.
- 5 15. A lancing device according to claim 14 wherein:  
said database allows the calculation of statistics for a profile.
16. A lancing device according to claim 9 or 14 wherein:  
said processor comprises an internal clock which links the lancing event  
with a time stamp.
- 10 17. A lancing device according to claim 9 wherein:  
said processor calculates an appropriate lancet diameter and geometry to  
collect a blood volume required by the user.
- 15 18. A method for lancing tissue comprising the steps of:  
selecting a desired profile from a set of alternative profiles having  
characteristic phases for lancet advancement and retraction;  
lancing a user according to said profile;  
determining a lancing profile trait during each of said characteristic  
20 phases; and  
optimizing said profile for subsequent lancing based upon said profile  
trait as a function of the characteristic phases for lancet advancement and  
retraction.
- 25 19. A method for lancing tissue according to claim 18 wherein:  
said profile trait comprises success of obtaining a blood sample from said  
user.
- 30 20. A method for lancing tissue according to claim 18 wherein:  
said profile trait comprises blood volume obtained from said user.



21. A method for lancing tissue according to claim 18 wherein:  
said profile trait comprises pain perceived by said user.
22. A method for lancing tissue according to claim 18 wherein:  
5 said profile trait comprises a relative time associated with skin deformation.
23. A method for lancing tissue according to claim 18 wherein:  
said profile trait comprises dwell time in said tissue of said user.  
10
24. A method for lancing tissue comprising the steps of:  
selecting a desired profile from a set of alternative profiles;  
lancing a user according to said profile;  
determining whether said lancing generated a blood sample result from  
15 said user;  
determining whether said lancing had success of obtaining a blood sample from said user;  
determining whether said lancing caused pain to said user;  
storing said blood sample result, said blood volume, and said pain  
20 determinations; and  
optimizing said profile for subsequent lancing.
25. A method for lancing tissue according to claim 24 further comprising the  
step of:  
25 prompting said user to choose between selecting another desired profile and selecting said optimized profile.
26. A method for lancing tissue according to claim 24 further comprising the  
step of:  
30 selecting a lancet diameter and geometry based on the optimizing of said profile.

27. A method for lancing tissue according to claim 18, wherein:  
said characteristic phases comprise a completed cycle of advancing and  
retracting said lancet into and out of a tissue to obtain a blood sample.
- 5
28. A method for lancing tissue according to claim 18, wherein:  
said characteristic phases further comprising:  
a lancet introduction phase comprising a longitudinal advancement  
of the lancet in a first direction into said tissue;  
10 a lancet rest phase comprising a termination of said longitudinal  
advancement of said lancet wherein said lancet reaches a  
maximum depth of tissue penetration and becomes relatively  
stationary; and  
a lancet retraction phase comprising a longitudinal retraction of  
15 said lancet in a second direction opposite said first direction out of said  
tissue.
29. A method for lancing tissue according to claim 28, wherein:  
said lancet introduction phase comprises a first time duration; and  
20 said lancet retraction phase comprises a second time duration which is  
relatively longer than said first time duration.
30. A method for lancing tissue according to claim 28, wherein:  
said lancet introduction phase further comprises:  
25 a lancet launch phase comprising a longitudinal advancement of  
the lancet in said first direction from a stationary loaded lancing  
position toward the tissue;  
a tissue contact phase including a point of initial contact between  
said distal end of said lancet and the tissue;  
30 a tissue deformation phase comprising deforming said tissue while  
longitudinally advancing said lancet in said first direction;

a tissue lancing phase comprising penetrating said tissue while longitudinally advancing said lancet in said first direction;

- 5           31. A method for lancing tissue according to claim 30, wherein:  
              said introduction phase varies according to said tissue deformation phase, such that said lancing follows said profile.
- 10           32. A method for lancing tissue according to claim 30, wherein:  
              said introduction phase varies according to said tissue contact phase, such that said lancing follows said profile.
- 15           33. A method for lancing tissue according to claim 28, wherein:  
              said lancet retraction phase further comprises:  
                  a primary lancet retraction phase comprising a longitudinal retraction of the lancet in said second direction from a relatively stationary position during said rest phase where said skin pushes said lancet in said second direction;  
                  a secondary lancet retraction phase comprising a longitudinal retraction of the lancet in said second direction from said position where said skin stops pushing said lancet in said second direction to a position and said lancet is pulled out of said skin in said second direction;  
                  and  
                  a lancet exit phase comprising an exit of the lancet from the skin.
- 20           34. A method for lancing tissue according to claim 33, wherein:  
              said retraction phase varies according to said primary retraction phase, such that said lancing follows said profile.
- 25

35. A method for lancing tissue according to claim 33, wherein:  
said retraction phase varies according to said secondary retraction phase,  
such that said lancing follows said profile.
- 5 36. A lancing device comprising:  
means for lancing tissue to obtain a blood sample;  
means for driving said lancing means; and  
means for controlling said driving means to provide a desired tissue  
lancing profile.
- 10 37. A method for lancing tissue to obtain a blood sample comprising the  
steps of:  
providing a lancet to puncture said tissue;  
attaching said lancet to a lancet driver for advancement and retraction of  
said lancet; and  
15 controlling said lancet advancement and retraction by modulating said  
lancet driver to vary said advancement and retraction as a function of  
relative position and motion of said lancet.
- 20 38. A lancing device according to claim 1 wherein:  
said feedback loop further comprises a light detecting sensor and a light  
emitter for monitoring the relative position of said lancet, said lancet  
further comprising a reflective surface on said proximal end such that  
said light emitter emits light such that said light is reflected from said  
25 reflective surface to said sensor.
- 30 39. A lancing device according to claim 1 wherein:  
said feedback loop further comprises an electromagnetic sensor for  
monitoring the relative position of at least one magnetically permeable  
region disposed on a region of said shaft, said sensor comprising at least  
one solenoid.

Figure 1A

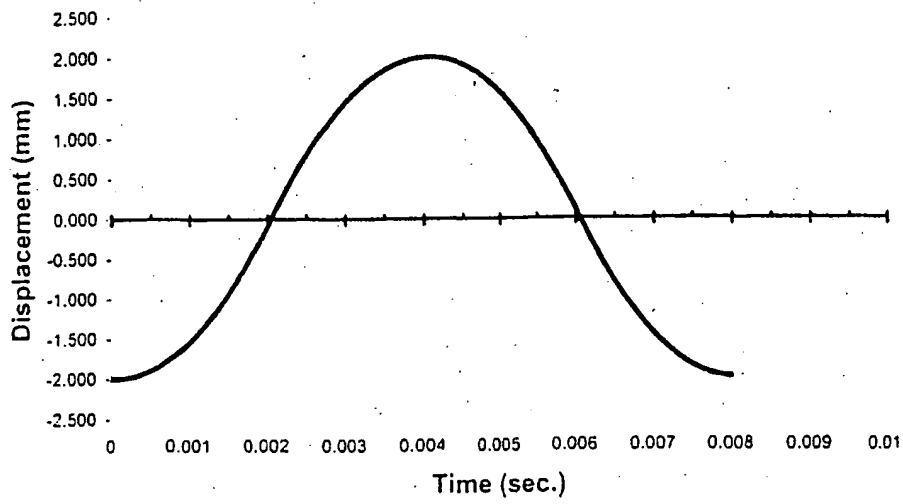
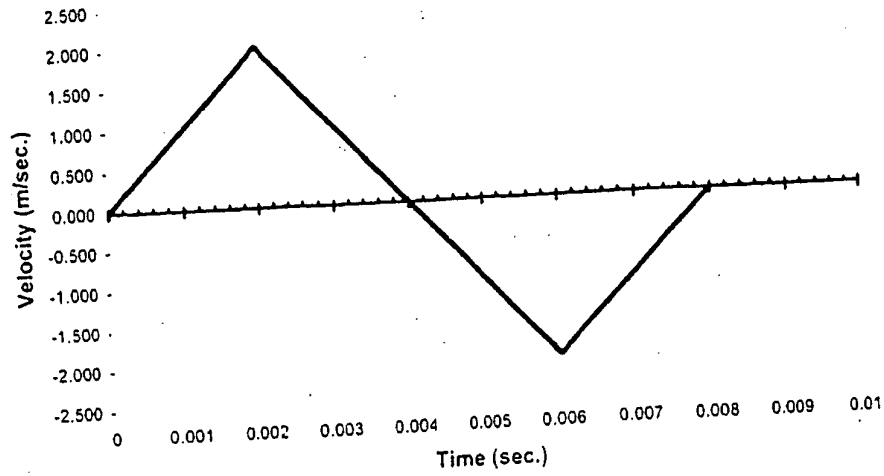
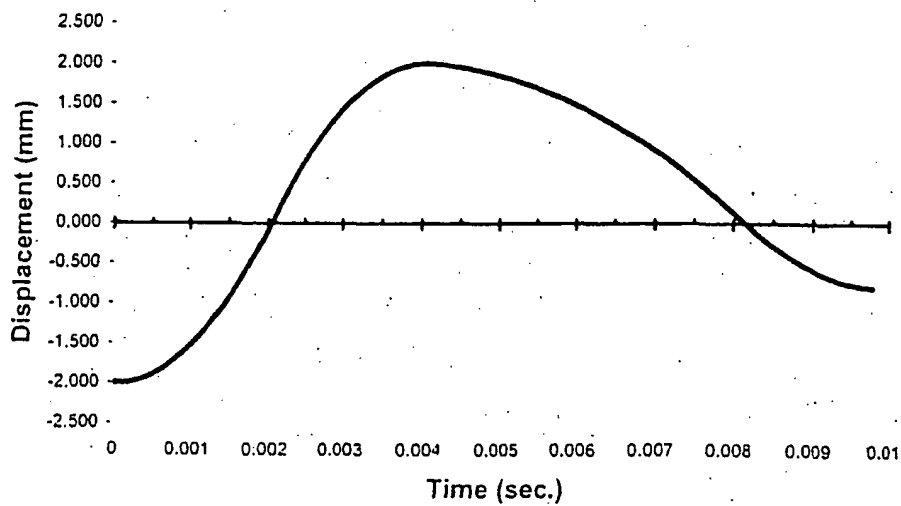

Figure 1B



3/7

Figure 2A



417

Figure 2B

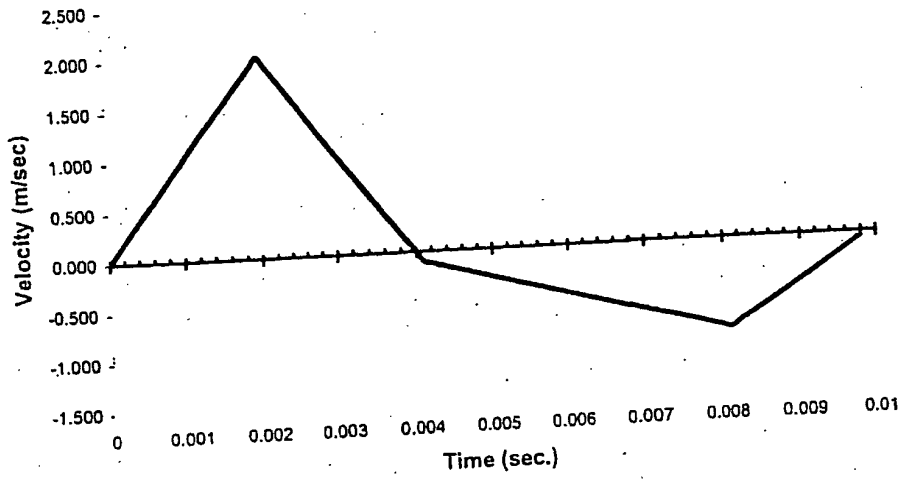



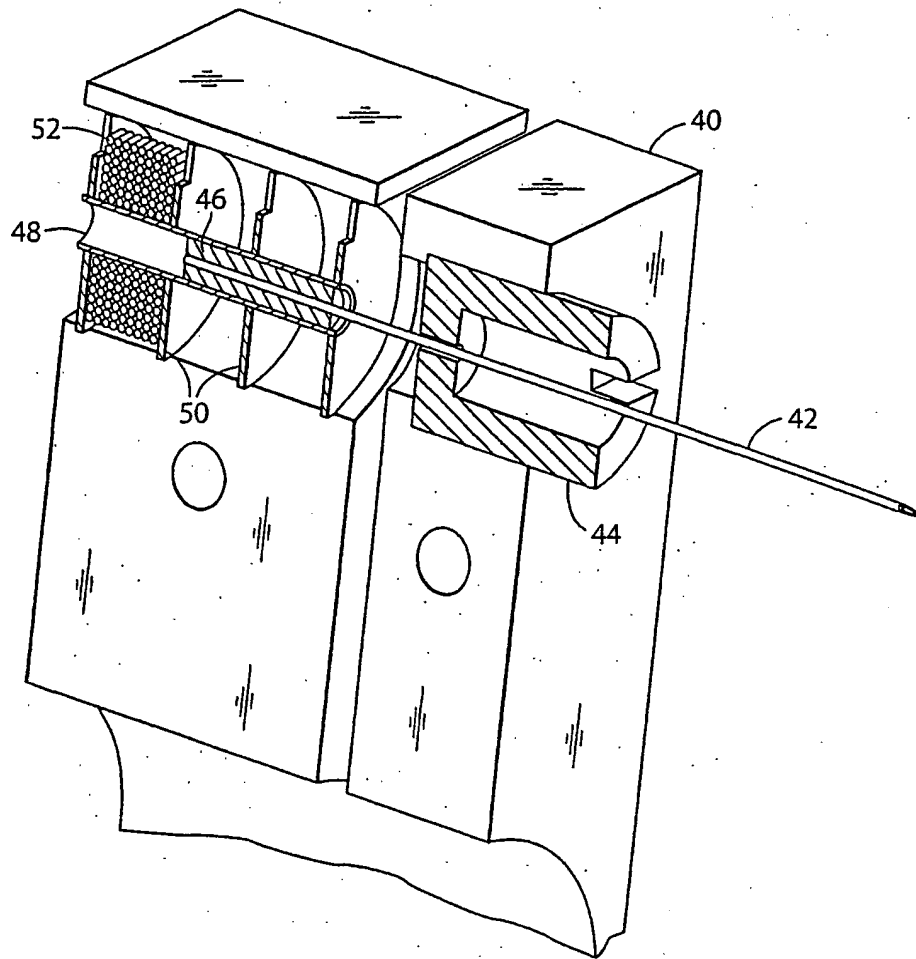

Figure 3

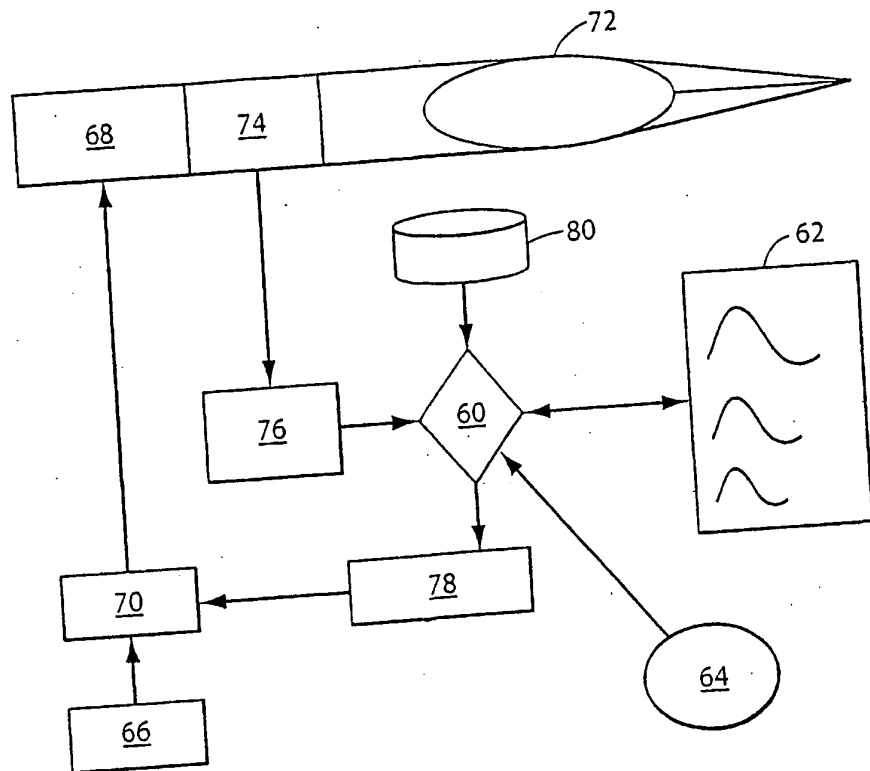

Figure 4

717

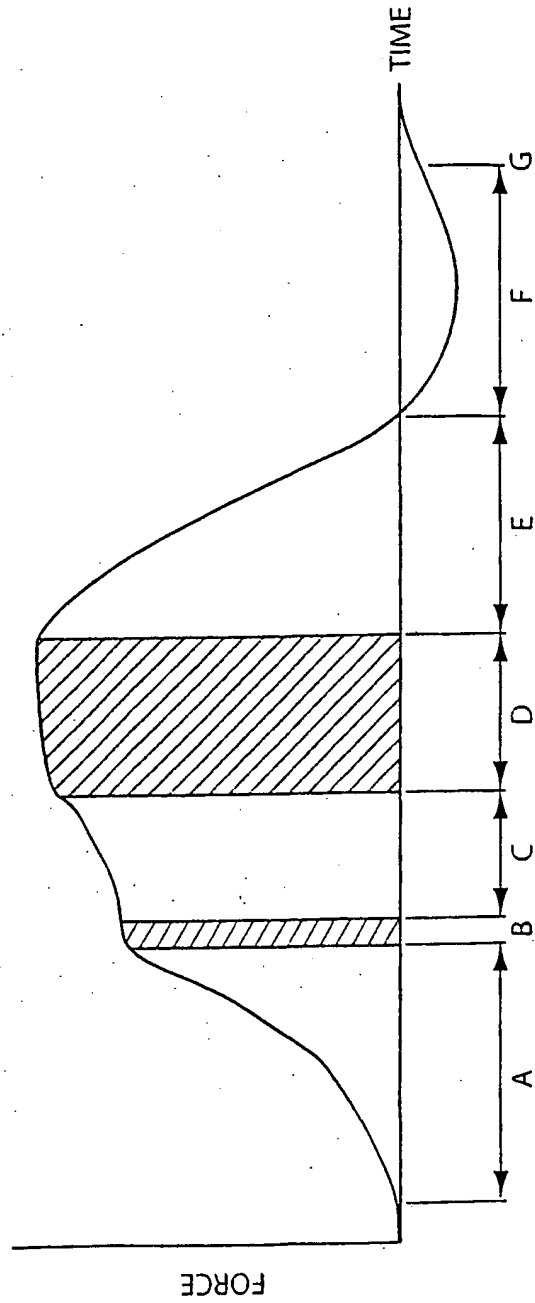

Figure 5

**BLANK PAGE**